

ASSA ABLOY is the global leader in door opening solutions, dedicated to satisfying end-user needs for security, safety and convenience



## Please Note:

This document is provided as a dimensional reference and should not be printed as a drilling template unless it can be correctly scaled to 100% by your printer.

ASSA ABLOY Australia Pty Limited  
235 Huntingdale Road,  
Oakleigh Victoria, 3166  
Australia

[info.au@assaabloy.com](mailto:info.au@assaabloy.com)  
[assaabloy.com.au](http://assaabloy.com.au)

ASSA ABLOY New Zealand Ltd.  
6 Armstrong Road  
Albany, North Shore City, 0632  
New Zealand

[info.nz@assaabloy.com](mailto:info.nz@assaabloy.com)  
[assaabloy.co.nz](http://assaabloy.co.nz)



# 530 DX SERIES DIGITAL ENTRANCE SET

## Lock mounting position.

This product is more convenient to operate at approximately chest level, but door construction may restrict the mounting position.

**SOLID DOORS:** Permit mounting at any height.

**HOLLOW CORE DOORS:** Mounting may be restricted by the size and position of the timber block within the door for lock mounting.

**Note:** For fire door applications, keypad must be fitted without rubber mounting pad.

## FOLLOW INSTRUCTIONS CAREFULLY

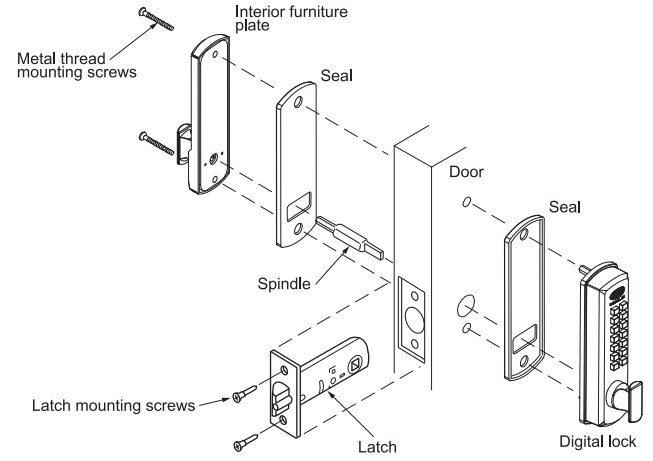

### 1. Prepare door and install latch.

- (a) Mark and drill holes as shown on template.
- (b) Insert latch into hole in door edge and scribe around faceplate.
- (c) Mortise 4mm (5/32") deep to accept latch faceplate.
- (d) Pre-drill 2.5mm (3/32") to accept mounting screws and secure latch using woodscrews supplied.

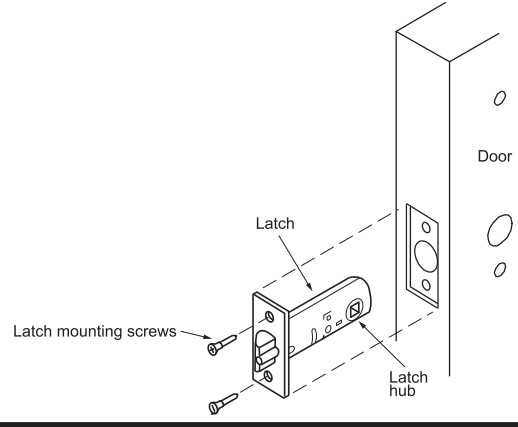

### 2. Install digital lock and interior furniture plate.

- (a) Fit rubber seal to the back of the digital lock and interior furniture plate.
- (b) Insert blade end of spindle in vertical position into digital lock drive gear.
- (c) Install digital lock and interior furniture plate to door with both turn knobs in vertical position.  
NOTE: Ensure that spindle engages latch hub and interior furniture plate drive gear.
- (d) Secure using two metal thread mounting screws.

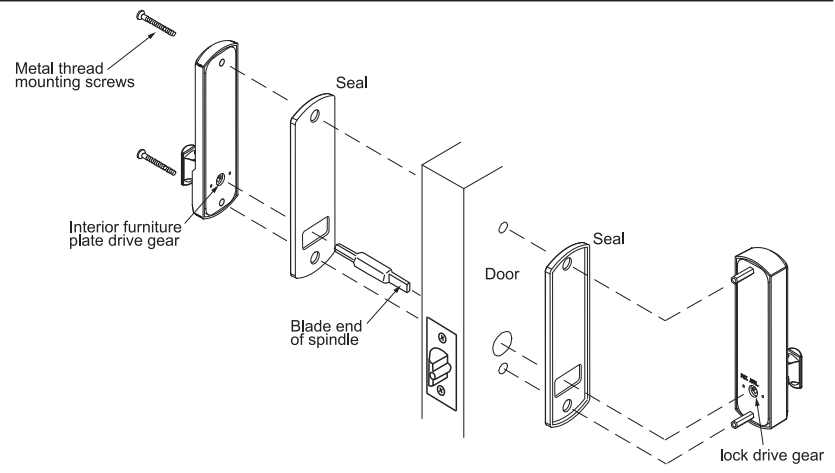

### 3. Prepare jamb and install strike.

- (a) Mark strike location on jamb edge directly opposite latch as shown.
- (b) Locate strike on jamb edge centrally about horizontal centreline with screw holes in strike on vertical centreline. Mark outline of strike and bolt hole onto jamb edge.
- (c) Mortise in the following sequence:
  - 1. Bolt hole mortise 16mm (5/8") deep.
  - 2. Strike mortise 1.5mm (1/16") deep.
- (d) Pre-drill 2.5mm (3/32") to accept mounting screws and secure using woodscrews supplied.

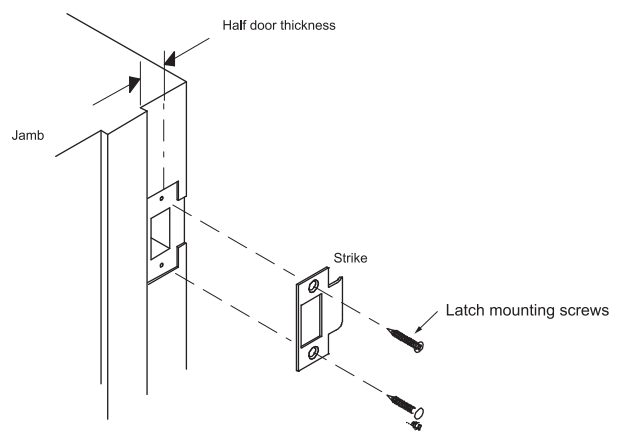

## LOCKWOOD GUARANTEE

## ASSA ABLOY

ASSA ABLOY Australia Pty Limited ("ASSA ABLOY") warrants its Lockwood products against defects in workmanship and materials, subject to the limitations and exclusions set out in this Warranty. If, within the normal working life of a product, it is found to be defective, and none of the limitations and exclusions set out in this Warranty apply, ASSA ABLOY will supply the same or equivalent product free of charge. This is the only remedy granted by ASSA ABLOY under this Warranty. **Limitations:** All electrical and electronic components used in ASSA ABLOY's Lockwood range of products (excluding batteries) are guaranteed for a period of 12 months from the date of proof of purchase, unless stated otherwise. **Exclusions:** This Warranty does not cover: 1. Damage to or malfunction or failure of the Lockwood product caused or contributed to by: (a) improper installation or failure to follow fitting instructions; (b) improper maintenance; (c) fair wear and tear; (d) any modification or repair which has not been authorized by ASSA ABLOY; (e) use of substitute or replacement parts or cylinders other than genuine ASSA ABLOY parts or cylinders; or (f) use of batteries other than those specified by ASSA ABLOY. 2. The cost of: (a) removal and/or replacement of the Lockwood product; (b) freight and/or travelling time; (c) replacement batteries; or (d) any modification or repairs to a Lockwood product, unless authorised by ASSA ABLOY. 3. Damage to or deterioration of the plated finishes Florentine Bronze, Architectural Bronze, Polished Brass, Gold and Satin Brass, which are classified as soft finishes, and are subject to deterioration under some environmental conditions. 4. Personal injury, property damage or economic loss, however caused. **Symmetry™ 5 Year Finish Warranty:** ASSA ABLOY Australia Pty Limited will replace five-year branded Symmetry product if within five years from the proven date of purchase it tarnishes, discolours or corrodes when properly installed and subject to no more than fair wear and tear. **Symmetry™ Everbrass® Warranty:** Everbrass® product is coated both on the exterior and interior surfaces with a lifetime anti-tarnish finish. ASSA ABLOY Australia Pty Limited will replace Everbrass® branded product if it corrodes, tarnishes or discolours when properly installed and subject to no more than fair wear and tear. This Warranty is in addition to and not in substitution for any rights of the purchaser under the Trade Practices Act and state or territory legislation.